

Linear Guideways

MG Series

2-3 MG Series - Miniature Linear Guideway

2-3-1 Features of MGN Series

1. Tiny and light weight, suitable for miniature equipment.
2. All materials in special grade of stainless steel for anti-corrosion size 9 and 12 are also available in alloy steel.
3. Gothic arch contact design can sustain the load from all directions and offer high rigidity and high accuracy.
4. Steel balls will be held by miniature retainer to avoid the balls from falling out even when the blocks are removed from the rail installation.
5. Interchangeable types are available in certain precision grades.

2-3-2 Construction of MGN Series

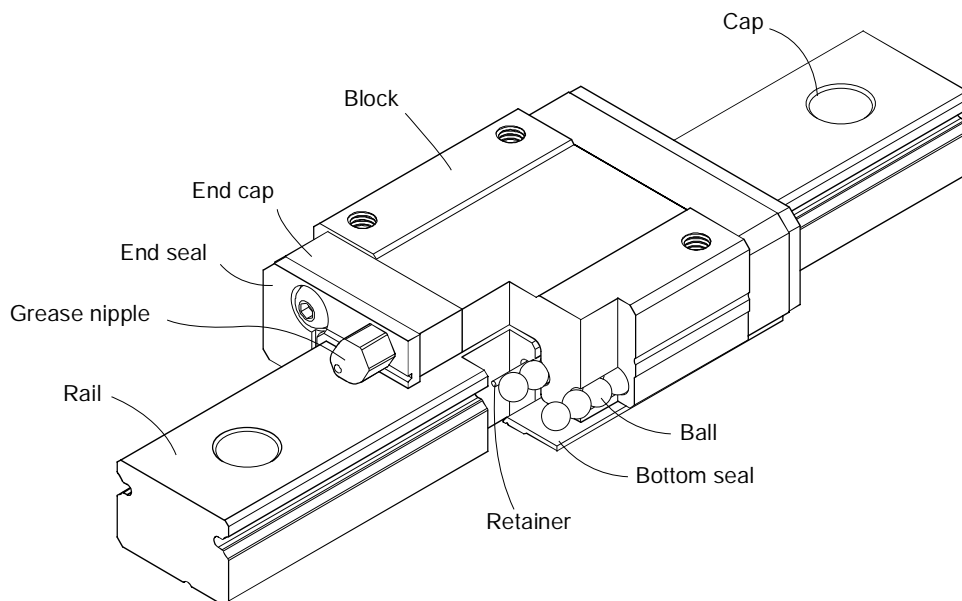

- Rolling circulation system: Block, rail, end cap and retainer
- Lubrication system: The grease nipple is available for MGN15, grease gun can be used for lubricating.
- Dust protection system: End seal, bottom seal (optional size 9,12,15), cap (size12,15)

2-3-3 Feature of MGW Series

The design feature of wide type miniature guideway-MGW:

1. The design of enlarged width has increased the capacity of moment load.
2. Gothic arch contact design has high rigidity characteristic in all directions.
3. Steel balls will be held by miniature retainer to avoid the balls from falling out even when the block are removed from the rail installation.
4. All metallic components are made of stainless steel for anti-corrosion purpose.

2-3-4 Configuration of MGW Series

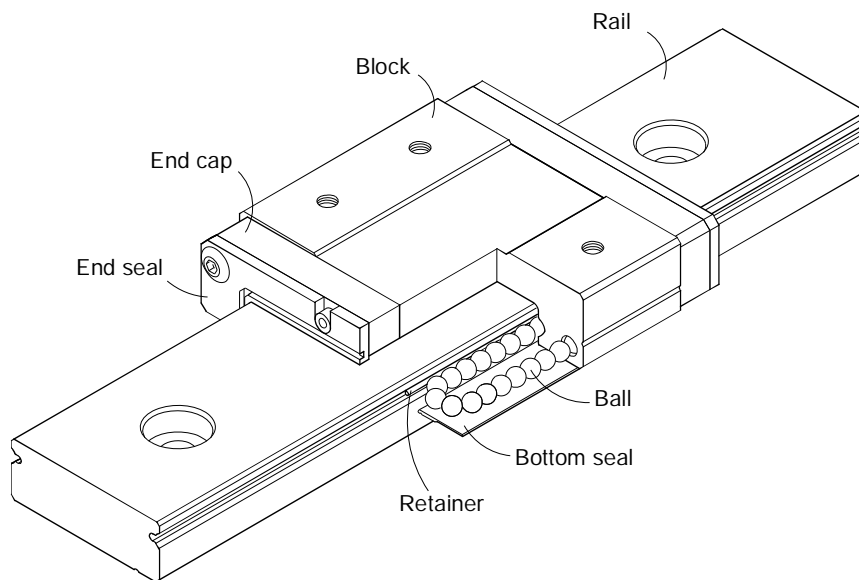

- Rolling circulation system: Block, rail, end cap and retainer
- Lubrication system: The grease nipple is available for MGW15, grease gun can be used for lubricating.
- Dust protection system: End seal, bottom seal (optional size 9,12,15), cap (size12,15)

2-3-5 Application

MGN/MGW series can be used in many fields, such as semiconductor equipment, PCB assembly equipment, medical equipment, robotics, measuring equipment, office automation equipment, and other miniature sliding machinery.

2-3-6 Model Number of MGN/MGW Series

MGN and MGW series linear guideway can be classified into non-interchangeable and interchangeable types. The sizes of two types are same. The interchangeable type is more convenient due to rails can be replaced. However, its precision is less than non-interchangeable type. Because of strict dimensional control, the interchangeable type linear guideway is a smart choice for customers when rails don't need to be paired for an axis. The model number contains the information of the size, type, accuracy class, preload class, and more.

Linear Guideways

MG Series

(1) Non-interchangeable type

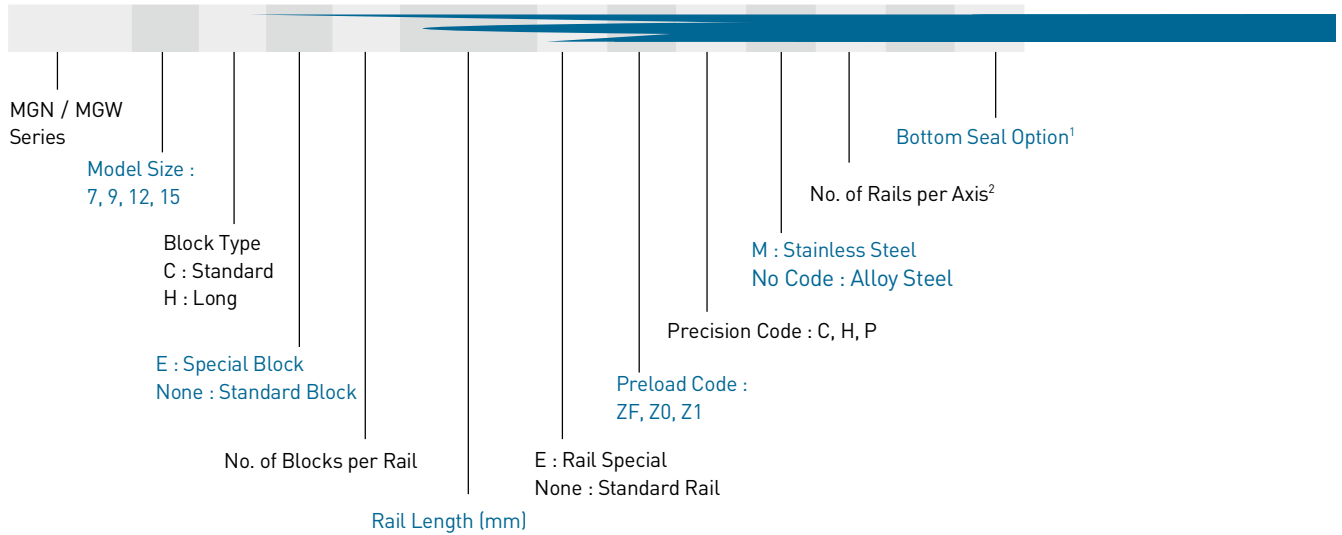

Note: 1. The bottom seal is available for MGN & MGW 9, 12, 15.
2. The roman numerals express the number of rails used in one axis. No symbol indicates single rail in an axis.

(2) Interchangeable type

○ Interchangeable Block

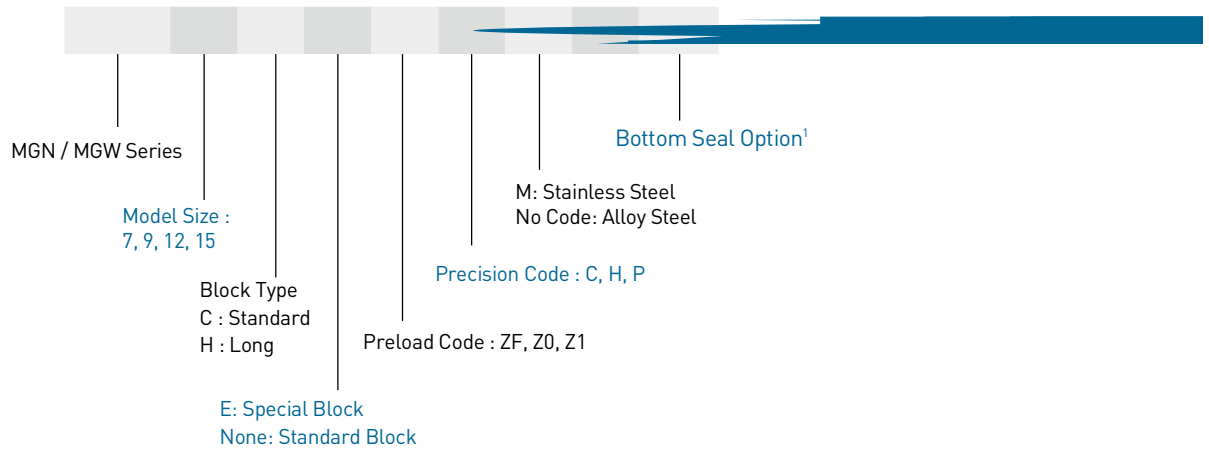

○ Interchangeable Rail

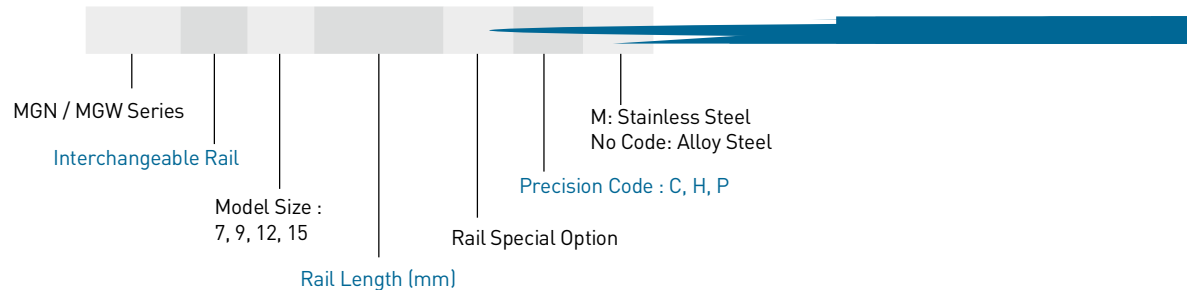

2-3-7 Accuracy Classes

The accuracy of MGN/MGW series can be classified into three classes: normal (C), high (H), precision (P), super precision(SP), ultra precision (UP). Customers can select the proper linear guideway by the required accuracy of the application.

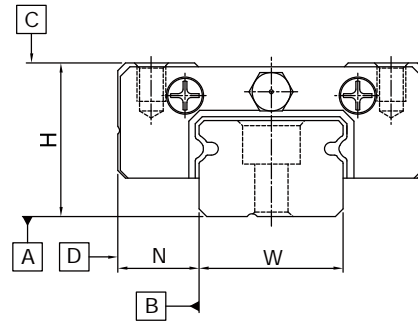

(1) Non-interchangeable

The accuracy values are taken at the central part of each block.

Table 2.47 Accuracy Standard of Non-interchangeable Type

Unit: mm

Accuracy Classes	Normal (C)	High (H)	Precision (P)
Dimensional tolerance of height H	± 0.04	± 0.02	± 0.01
Dimensional tolerance of width N	± 0.04	± 0.025	± 0.015
Pair Variation of height H	0.03	0.015	0.007
Pair Variation of width N (Master Rail)	0.03	0.02	0.01
Running parallelism of block surface C to surface A	According to Table 2.49		
Running parallelism of block surface D to surface B	According to Table 2.49		

(2) Interchangeable

Height variation between the interchangeable and non-interchangeable types is minimal.

Table 2.48 Accuracy Standard of Interchangeable Type

Unit: mm

Accuracy Classes	Normal (C)	High (H)	Precision (P)
Dimensional tolerance of height H	± 0.04	± 0.02	± 0.01
Dimensional tolerance of width N	± 0.04	± 0.025	± 0.015
One Set	Pair Variation of height H	0.03	0.015
	Pair Variation of width N	0.03	0.02
Pair Variation of width N (Master Rail)	0.07	0.04	0.02
Running parallelism of block surface C to surface A	According to Table 2.49		
Running parallelism of block surface D to surface B	According to Table 2.49		

Linear Guideways

MG Series

(3) Accuracy of running parallelism

The running parallelism C to A and D to B are related to the rail length.

Table 2.49 Accuracy of Running Parallelism

Rail Length			Accuracy (μm)			Rail Length			Accuracy (μm)		
(mm)	(C)	(H)	(P)	(mm)	(C)	(H)	(P)				
50 & under	12	6	2	315 ~ 400	18	11	6				
50 ~ 80	13	7	3	400 ~ 500	19	12	6				
80 ~ 125	14	8	3.5	500 ~ 630	20	13	7				
125 ~ 200	15	9	4	630 ~ 800	22	14	8				
200 ~ 250	16	10	5	800 ~ 1,000	23	16	9				
250 ~ 315	17	11	5	1,000 ~ 1,200	25	18	11				

2-3-8 Preload

MGN/MGW series provide three preload levels for various applications.

Table 2.50 Preload Classes

Class	Code	Preload	Accuracy
Light Clearance	ZF	Clearance 4~10 μm	C
Very Light Preload	Z0	0	C~P
Light Preload	Z1	0.02C	C~P

Note: "C" in column preload means basic dynamic load rating.

2-3-9 Dust Proof Accessories

End seals and standard accessories fixed on both sides of the block can prevent dust from entering the block, so the accuracy and service life of a linear guideway can be maintained. Bottom seals are fixed under the skirt portion of the block to prevent dust from entering. Customers can order bottom seals by adding the mark "+U" followed by the model number. Sizes 12 and 15 provide bottom seals as an option, but sizes 7 and 9 do not offer the option due to the space limit of H_1 . If the linear guideway is equipped with a bottom seal, the lateral mounting surface of the rail must not exceed H_1 .

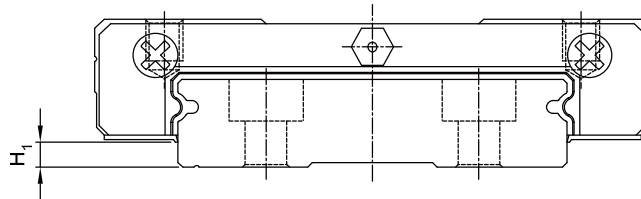

Table 2.51

Size	Bottom seal	H_1 , mm
MGN 7	-	-
MGN 9	-	-
MGN 12	●	2
MGN 15	●	3
MGW 7	-	-
MGW 9	-	-
MGW 12	●	2.6
MGW 15	●	2.6

2-3-10 Cautions for Installation

- Shoulder heights and fillets

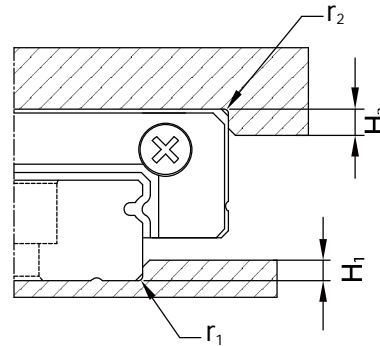

Table 2.52 Shoulder Heights and Fillets

Size	Max. radius of fillets r_1 (mm)	Max. radius of fillets r_2 (mm)	Shoulder height H_1 (mm)	Shoulder height H_2 (mm)
MGN 7	0.2	0.2	1.2	3
MGN 9	0.2	0.3	1.7	3
MGN 12	0.3	0.4	1.7	4
MGN 15	0.5	0.5	2.5	5
MGW 7	0.2	0.2	1.7	3
MGW 9	0.3	0.3	2.5	3
MGW 12	0.4	0.4	3	4
MGW 15	0.4	0.8	3	5

- Tightening torque of bolts for installation

Improperly tightening the rail mounting bolts will seriously affect the accuracy of the linear guideway. The following table lists the recommended tightening torque for the specific sizes of bolts.

Table 2.53 Tightening Torque

Size	Bolt size	Torque (kgf-cm)
MGN 7	M2	5.9
MGN 9	M3	19
MGN 12	M3	19
MGN 15	M3	19
MGW 7	M3	19
MGW 9	M3	19
MGW 12	M4	40
MGW 15	M4	40

Linear Guideways

MG Series

2-3-11 Standard and Maximum Lengths of Rail

HIWIN stocks standard lengths of rail. If a non-standard length is required, it is recommended to specify the E value to be not greater than 1/2 of the pitch (P) to avoid instability at the end of the rail, and the E value should not be less than E_{min} in order to prevent breaking the end mounting hole.

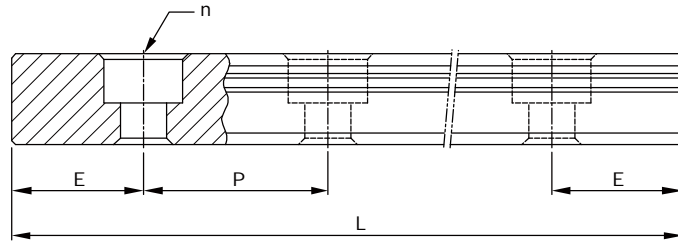

$$L = (n-1) \times P + 2 \times E \quad \text{Eq.2.3}$$

- L : Total length of rail (mm)
- n : Number of mounting holes
- P : Distance between any two holes (mm)
- E : Distance from the center of the last hole to the edge (mm)

Table 2.54

unit: mm

Item	MGNR	MGNR	MGNR	MGNR	MGWR	MGWR	MGWR	MGWR
	7M	9M	12M	15M	7M	9M	12M	15M
Standard Length L(n)	40(3)	55(3)	70(3)	70(2)	80(3)	80(3)	110(3)	110(3)
	55(4)	75(4)	95(4)	110(3)	110(4)	110(4)	150(4)	150(4)
	70(5)	95(5)	120(5)	150(4)	140(5)	140(5)	190(5)	190(5)
	85(6)	115(6)	145(6)	190(5)	170(6)	170(6)	230(6)	230(6)
	100(7)	135(7)	170(7)	230(6)	200(7)	200(7)	270(7)	270(7)
	130(9)	155(8)	195(8)	270(7)	260(9)	230(8)	310(8)	310(8)
		175(9)	220(9)	310(8)		260(9)	350(9)	350(9)
		195(10)	245(10)	350(9)		290(10)	390(10)	390(10)
		275(14)	270(11)	390(10)		350(14)	430(11)	430(11)
		375(19)	320(13)	430(11)		500(19)	510(13)	510(13)
			370(15)	470(12)		710(24)	590(15)	590(15)
			470(19)	550(14)		860(29)	750(19)	750(19)
		570(23)	670(17)			910(23)	910(23)	
		695(28)	870(22)			1070(27)	1070(27)	
Pitch (P)	15	20	25	40	30	30	40	40
Distance to End (E _s)	5	7.5	10	15	10	10	15	15
Max. Standard Length	595(40)	995(40)	995(40)	990(25)	590(20)	980(33)	1150(29)	1150(29)
Max. Length	600	1000	1000	2000	600	1000	1200	2000

- Note:
1. Tolerance of E value for standard rail is 0.5--0.5 mm. Tolerance of E value for jointed rail is 0--0.3 mm.
 2. Maximum standard length means the max. rail length with standard E value on both sides.
 3. The specification with "M" mark are stainless steel and without "M" mark are alloy steel.
 4. If smaller E value is needed, please contact HIWIN.

2-3-12 Dimensions for MGN/MGW Series

(1) MGN-C / MGN-H

MGN7, MGN9, MGN12

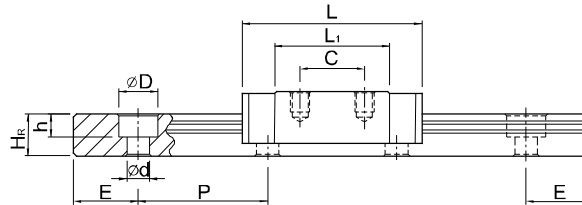
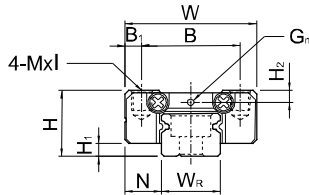

MGN15

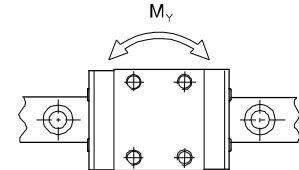
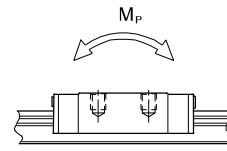
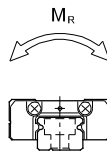
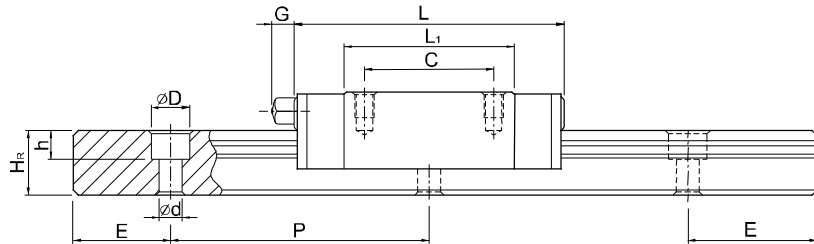
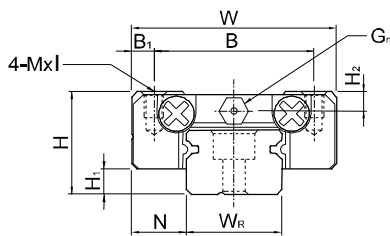

Model No.	Dimensions of Assembly (mm)		Dimensions of Block (mm)										Dimensions of Rail (mm)						Mounting Bolt for Rail (mm)	Basic Dynamic Load Rating C (kgf)	Basic Static Load Rating C ₀ (kgf)	Static Rated Moment			Weight			
	H	H ₁	N	W	B	B ₁	C	L ₁	L	G	G ₁	MxI	H ₂	W _R	H _R	D	h	d				P	E	M _R	M _P	M _Y	Block g	Rail kg/m
																									kgf-m	kgf-m	kgf-m	
MGN 7C	8	1.5	5	17	12	2.5	8	13.5	22.5	-	Ø1.2	M2x2.5	1.5	7	4.8	4.2	2.3	2.4	15	5	M2x6	100	127	0.48	0.29	0.29	10	0.22
MGN 7H							13	21.8	30.8													15						
MGN 9C	10	2	5.5	20	15	2.5	10	18.9	28.9	-	Ø1.2	M3x3	1.8	9	6.5	6	3.5	3.5	20	7.5	M3x8	190	260	1.2	0.75	0.75	16	0.38
MGN 9H							16	29.9	39.9													26						
MGN 12C	13	3	7.5	27	20	3.5	15	21.7	34.7	-	Ø1.4	M3x3.5	2.5	12	8	6	4.5	3.5	25	10	M3x8	290	400	2.6	1.4	1.4	34	0.65
MGN 12H							20	32.4	45.4													54						
MGN 15C	16	4	8.5	32	25	3.5	20	26.7	42.1	4.5	M3	M3x4	3	15	10	6	4.5	3.5	40	15	M3x10	470	570	4.6	2.2	2.2	59	1.06
MGN 15H							25	43.4	58.8													92						

Linear Guideways

MG Series

(2) MGW-C / MGW-H

MGW7, MGW9, MGW12

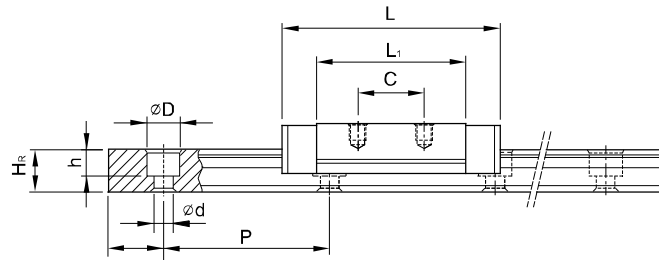
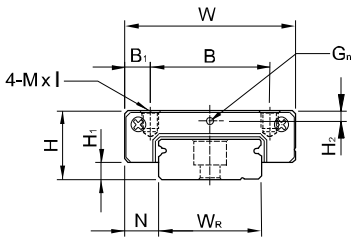

MGW15

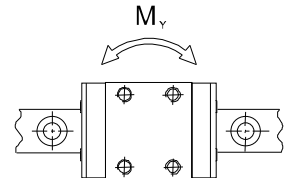
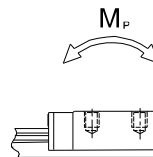
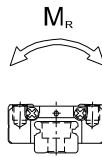
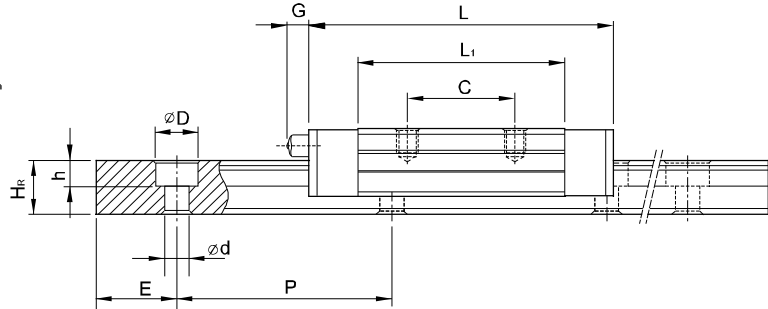
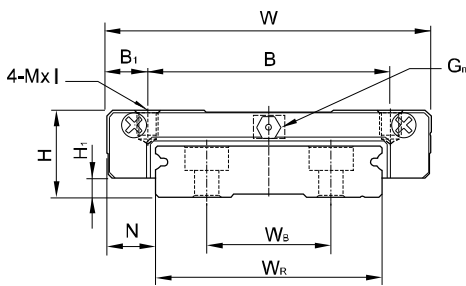

Model No.	Dimensions of Assembly (mm)			Dimensions of Block (mm)										Dimensions of Rail (mm)						Mounting Bolt for Rail (mm)	Basic Dynamic Load Rating C (kgf)	Basic Static Load Rating C ₀ (kgf)	Static Rated Moment			Weight					
	H	H ₁	N	W	B	B ₁	C	L ₁	L	G	G _n	MxI	H ₂	W _R	W _S	H _R	D	h	d				P	E	M _R	M _P	M _Y	Block	Rail		
	kgf-m	kgf-m	kgf-m	g	kg/m																										
MGW 7C	9	1.9	5.5	25	19	3	10	21	31.2	-	Ø1.2	M3x3	1.85	14	-	5.2	6	3.2	3.5	30	10	M3x6	140	210	1.6	0.73	0.73	20	0.51		
MGW 7H							19	30.8	41														180	320	2.39	1.58	1.58	29			
MGW 9C	12	2.9	6	30	23	3.5	21	4.5	12	27.5	39.3	-	Ø1.4	M3x3	2.4	18	-	7	6	4.5	3.5	30	10	M3x8	280	420	4.09	1.93	1.93	40	0.91
MGW 9H							23	38.5	50.7	350	600														5.56	3.47	3.47	57			
MGW 12C	14	3.4	8	40	28	6	15	31.3	46.1	-	Ø1.4	M3x3.6	2.8	24	-	8.5	8	4.5	4.5	40	15	M4x8	400	570	7.17	2.83	2.83	71	1.49		
MGW 12H							28	45.6	60.4														520	840	10.47	5.85	5.85	103			
MGW 15C	16	3.4	9	60	45	7.5	20	38	54.8	5.2	M3	M4x4.2	3.2	42	23	9.5	8	4.5	4.5	40	15	M4x10	690	940	20.32	5.78	5.78	143	2.86		
MGW 15H							35	57	73.8														910	1410	30.48	12.5	12.5	215			